

BOSCOPI, INC.

BVS2001 Series

OPERATORS MANUAL COIN, BILL AND CARD



Boscop, Inc.
159 Dana Hill Road
New Hampton, NH 03256
Phone: 603-744-7979
Fax: 603-744-2062
Web Site: www.boscop.com

At **Boscop, Inc.**, complete customer satisfaction is our number one goal. As such, customer support is readily available to satisfy any need you may have. Whether it's sales information, a service requirement or just general inquiry, you can be assured of a prompt response to your need(s).

If you require technical assistance advice or parts please contact your Boscop, Inc. Sales and Service office and ask for the service department.

If you are a new or existing customer with a new installation in mind, our highly qualified sales staff will custom tailor a product solution for "your" particular needs. Simply telephone Boscop, Inc. in the United States at 800-229-8765 and ask for sales assistance.

UNITED STATES

Boscop, Inc.
159 Dana Hill Road
New Hampton, NH 03256
Phone: 603-744-7979
Fax: 603-744-2062
Web Site: www.boscop.com

Boscop, Inc. . . . COMMITTED TO COMPLETE CUSTOMER SATISFACTION

Table of Contents

SALES AND SERVICE	2
TABLE OF CONTENTS	3
INTRODUCTION	4
SET-UP	5
Programming Switches.....	5
Loading The Coin Tubes.....	6
Topping Off The Coin Tubes.....	6
BYPASS/PROGRAMMING MODE	7
Coin Tube (Inventory) Mode.....	7
Language Mode.....	7
Diagnostics Mode.....	7
Peripherals Mode.....	8
Coin Changer Mode.....	8
Bill Acceptor Mode.....	8
Card Reader Mode.....	9
Card Formats.....	10
Setting The STX and ROM	11
Costs Mode.....	12
Interface Mode.....	15
Bonus Mode.....	18
Set PDA Password.....	18
READ METERS	19
PRINTING THE METERS	22
Printer Cable.....	22
Seiko DPU 414 Printer Settings.....	22
PC Cable.....	22
Sample Reports From Serial Port.....	23
INSTALLATION	24
Placement Of The Coin, Bill and Card Controller.....	24
Connecting To Power.....	24
Enable.....	24
Pulse.....	25
Chassis Ground.....	25
Special Considerations.....	25
Using A Paper Clutch.....	25
Second Price (i.e. Large Paper) Connection.....	26
-“Line 2 LEVEL Mode”.....	26
-“Line 2 PULSE Mode”.....	26
-“Line 2 PREMIUM Mode”.....	27
WARRANTY AND LIABILITY CONTRACT	28

INTRODUCTION

Three models of Coin Copy Controllers are offered. They are the **2001 coin, 2002 coin and bill, and the 2003 coin, bill and card.**

When power is applied to the controller, the display will briefly display “**Initializing peripherals**”. A message “**M52X0 V 1.XX**” will indicate the model and firmware version.

Once the Controller is completely initialized it will enter “idle” mode. Idle mode is the normal condition of the Coin box when it is waiting for Credit. The display will indicate: “**Insert Cash**”. If the Coin box is outfitted with a card reader it will display “**Insert Cash or Card**”.

If the coin box has been installed and set-up, inserting cash or a valid card at this time will enable the copier. The LCD display will indicate the value of credit remaining and the number of copies that can be made based upon the prices set in memory. Pressing the Eject Plunger will cause the Coin box to return the card or coins.

The “**Out of Change**” LED may be lit indicating that there is insufficient change in the Coin Changer to pay-out or the coin inventory was incorrectly added.

If the Display indicates “**Bypass Mode Copies X**” the Bypass/Programming mode has been initiated by turning the Key-switch beside the Display. The Bypass/Programming mode is described in full later in this manual.

SET-UP

Programming Switches

Opening the Front door will gain access to the programming switches; Menu, Enter, Up and Down. The view below is from “inside” the coin box; therefore, looking from the front and reaching into the Coin Box, these switches will be reversed (Menu on the Right). The Switches are located inside the upper left corner above the “**Out of Change**” LED and LCD Display. The Menu button steps through different menus. The Enter button sets the current value displayed in memory and advances to the next menu or function. The UP and Down buttons are used to change the current value displayed. Note pressing the **UP** button while the **Down** button is depressed will clear the current value to Zero.

Turning the “Key-switch on top of the Coin box will initiate Bypass/Programming mode.

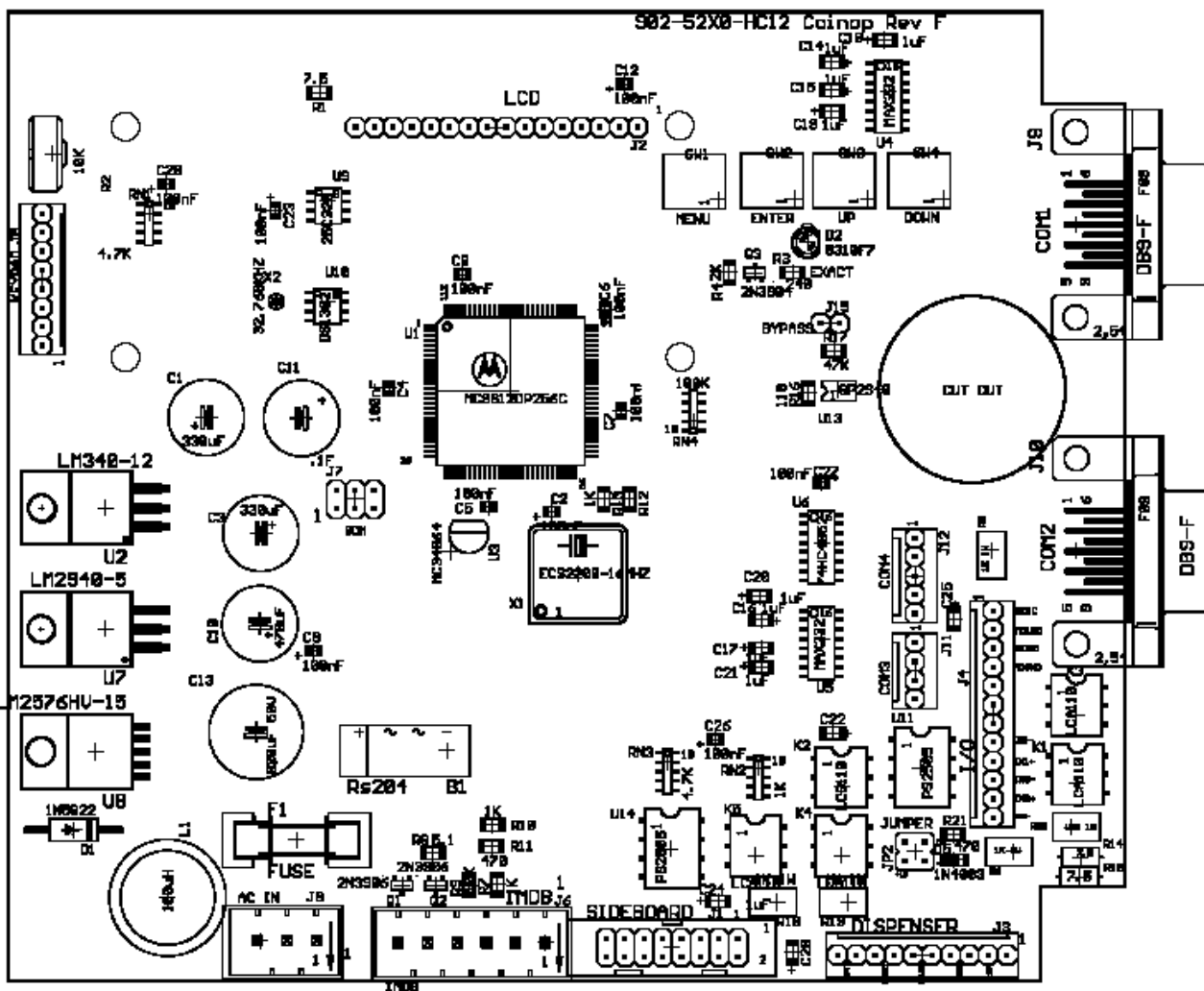

Loading the Coin Tubes

To initially load the tubes it is permissible to load coins directly into the Coin changer's Inventory tubes. Fill the tubes with a known quantity of each coin. After loading the tubes the quantity of each coin must be programmed into memory. Press the "**MENU**" button on the main control board. The display will indicate "**Coin Tubes**" then " \$.25, .10, .05"

"XXX XXX XXX XXX"

(Note the \$ Coin will only be indicated if the Coin Box is fitted with a 4 Tube Changer capable of inventorying One Dollar coins)

Press the "**ENTER**" button.

To adjust the **Dollar Coin tube** (if applicable) press the "**UP**" or "**Down**" button until the correct value is displayed on the LCD.

Press the "**ENTER**" button.

To adjust the **Quarters tube** level press the "**UP**" or "**Down**" button until the correct value is displayed on the LCD.

Press the "**ENTER**" button.

To adjust the **Dimes tube** level press the "**UP**" or "**Down**" button until the correct value is displayed on the LCD.

Press the "**ENTER**" button.

To adjust the **Nickels tube** level press the "**UP**" or "**Down**" button until the correct value is displayed on the LCD.

Press the "**ENTER**" button.

Topping Off the Coin Tubes

To add coins to the partially filled tubes it may be done by first turning the "BYPASS KEY" then, press the "**MENU**" Button. The display will indicate: " \$.25 .10 .05"

"XXX XXX XXX XXX"

As coins are inserted the appropriate value will increment. Turn the bypass key to off when finished to record new values and exit the mode. Any coins added in this mode will be added to the total coin count automatically. Coins added directly to the inventory tubes will not be counted causing false "Out Of Change" situations.

BYPASS/PROGRAMMING MODE

By turning the “**BYPASS KEY**” and pressing the “**MENU**” button it is possible to step to a specific setup function without going through all. The functions available in Programming mode are:

Coin Tube Levels	Language	Diagnostics Mode
Peripherals	Coin Changer	Bill Acceptor
Card Reader	Costs	Interface
Bonus		

To initiate the “Bypass/Programming” mode, turn the “**BYPASS KEY**” 90 degrees clockwise. The display will indicate: “**Bypass Mode**” “**Copies X**”. In Bypass mode the copier is “enabled” to allow copies. Any copies made in the bypass mode are recorded as “Bypass Copies” by the Coin box meters. The meters are described in detail later in this manual.

To initiate the programming mode, press the “**MENU**” button on the CPU board.

Coin Tube (Inventory) Mode

In Coin Tube Inventory mode the display will show: “.25 .10 .05”

“**XXX XXX XXX**”

Indicating the current number of coins in each of the coin changer’s Inventory tubes. Coins can be added through the coin slot at this time and the coins will be added to the appropriate values.

Press the “**MENU**” button to continue.

Language Mode

The display will indicate whether the controller is set up for French or English prompts. To change the setting, press the “**UP**” or “**DOWN**” button.

Press the “**Enter**” or “**Menu**” button to continue.

Diagnostics Mode

Pressing the “**ENTER**” button twice while Diagnostics is displayed on the LCD will cause the VS-2000 to perform a self-test. The first message will indicate the firmware model and version. The main board will then attempt to communicate with the coin changer, bill acceptor and card reader. Any device that is attached and operational will report its status and where applicable, current settings. This is an information only mode and no settings can be made but the data displayed can be used for troubleshooting the devices. After reporting the status of the coin changer, bill acceptor then card reader the display will show “**System Diag Tests**”.

Turn off the bypass key at this time as proceeding will cause the coin box to go into a Factory Test mode where further hardware is required.

Peripherals Mode

The bill acceptor and the card reader are considered peripherals.

Press the “**ENTER**” button and the display will indicate **bill acceptor**. Press the “**UP**” or “**DOWN**” buttons to activate, “**yes**”, or deactivate, “**no**”.

Press the “**ENTER**” button and the display will indicate **card reader**. Press the “**UP**” or “**DOWN**” buttons to activate, “**yes**”, or deactivate, “**no**”.

Press the “**ENTER**” or “**Menu**” button to continue.

Coin Changer Mode

– Press the “**ENTER**” button.

The display will indicate the current **Return Escrow** Option. Use the “**UP**” or “**DOWN**” buttons to cause the unit to give change “Anytime”, “Only After Use”, or, give change function is managed by “serial control” (for print manager applications).

Press the “**ENTER**” button and the display will indicate **Max Escrow Value**. To increase it, press the “**UP**” button. To decrease it, press the “**DOWN**” button. This will limit the amount of money deposited in Escrow so that when the return button is pressed, there will not be so many coins required for payout.

Press the “**ENTER**” button and the display will indicate **Min Escrow Value** for Coins. To increase it, press the “**UP**” button. To decrease it, press the “**DOWN**” button. The Min Escrow should usually be set at 0.00 to indicate it is not used. In the case where the coin box should not enable until a minimal amount of value is available in escrow that value can be set as the “Min Escrow”.

Press the “**ENTER**” button and the display will indicate **ESCROW<P2=Cancel!**. Press the “**UP**” or “**DOWN**” buttons to activate, “**yes**”, or deactivate, “**no**”. With this set to **YES** when the unused credit held in escrow drops below the value of price 2 copies, the coins or card are returned and the session is cancelled as if the eject plunger were pressed.

Press the “**MENU**” button to continue.

Bill Acceptor Mode

– Press the “**ENTER**” button.

Use the “**UP**” or “**DOWN**” buttons to enable “**YES**” or disable “**NO**” the **acceptance of \$1 bill**. Then press the “**ENTER**” button.

Use the “**UP**” or “**DOWN**” buttons to enable “**YES**” or disable “**NO**” the **acceptance of \$2 bill**. Then press the “**ENTER**” button.

Use the “**UP**” or “**DOWN**” buttons to enable “**YES**” or disable “**NO**” or enable “**only with card**” the **acceptance of \$5 bill**. Then press the “**ENTER**” button.

Use the “**UP**” or “**DOWN**” buttons to enable “**YES**” or disable “**NO**” or enable “**only with card**” the **acceptance of \$10 bill**. Then press the “**ENTER**” button.

Use the “UP” or “DOWN” buttons to enable “YES” , disable “NO” or enable “only with card” the acceptance of \$20 bill. Then press the “ENTER” button.

*** NOTE the bill denominations accepted will be limited by the model of bill acceptor installed and its internal settings.**

Press the “MENU” button to continue.

Card Reader Mode

– Press the “ENTER” button.

To increase the Max Card Value allowed (for Cash cards); use the “UP” button. To decrease, use the “DOWN” button.

Any card inserted that exceeds the “Max” will be rejected. The coin box will not allow money to be added to the card that would exceed the “Max”.

Press the “ENTER” button.

To increase the Max Unit Value allowed (for Units cards); use the “UP” button. To decrease, use the “DOWN” button.

Any card inserted that exceeds the “Max” will be rejected. The coin box will not allow money to be added to the card that would exceed the “Max”.

Press the “ENTER” button.

To increase the Cents per Units (value needed to add 1 Unit to a card), use the “UP” button. To decrease, use the “DOWN” button.

Press the “ENTER” button.

To allow the unit to add value to cards by coins, press the “UP” button. To disallow, press the “DOWN” button.

Press the “ENTER” button.

To allow the unit to add value to cards by bills, press the “UP” button. To disallow, press the “DOWN” button.

Press the “ENTER” button.

To allow the unit to add value to UNITS cards, press the “UP” button. To disallow, press the “DOWN” button.

Press the “ENTER” button.

To allow the unit Display the card value to the tenth of a cent, press the “UP” button for “Yes” or the “DOWN” button for “No”.

Press the “ENTER” button.

Card Formats

To set the **Reader format**, press the “**UP**” or “**Down**” button until the correct card format is displayed on the LCD. The reader format must be set to “**ITC/ACT**” in order to accept multiple card formats or to convert other cards (ICS/XCP/Danyl) to the ITC card format.

Press the “**ENTER**” button.

Set **Accept ICS/XCP** to “**YES**”, “**NO**” or “**Convert to ITC**”. If using “Convert to ITC”, the card will be re-formatted to the ITC format to take advantage of the increased security and integrity BUT the cards **will no longer work** in old ICS or XCP manufactured readers.

Press the “**ENTER**” button.

Set **Accept Danyl** to “**NO**”, “**Convert to Site 1**” or “**Convert to Site 2**”. If using “Convert to Site 1” or “2” is selected, the card will be re-formatted to the ITC format (to the appropriate site) to take advantage of the increased security and integrity BUT the cards **will no longer work** in old Danyl manufactured readers. Any value on the card(s) that are converted will be reflected in the meter “Danyl Value Conv”

Press the “**ENTER**” button.

** A specially constructed card reader is required to accept Danyl cards. Contact Boscop for details.

Setting the STX and ROM

A two nibble (four bit) code forms part of the overall facility code. This has typically been referred to as the “**ROM**” code for the site. The first nibble of this “**ROM**” code has typically been referred to as the Start (first nibble, **STX**).

Each nibble of the two nibble “**ROM**” code can have a value from “**0**” to “**F**” in hexadecimal notation, which is “**0**” to “**15**” in decimal notation. The values set in the coin box must be in decimal notation. I.E. “**ROM**” Code of “**B9**”. The **STX** nibble is “**B**” (11) and the **ROM** nibble is “**9**” (9). See table below:

<u>Specified STX or ROM (Hex)</u>	<u>Decimal Value to Enter</u>	<u>Common “ROM” Combinations</u>	<u>STX Setting</u>	<u>ROM Setting</u>
0	0	B9	11	9
1	1	C0	12	0
2	2	C1	12	1
3	3	C2	12	2
4	4	C5	12	5
5	5	C6	12	6
6	6	40	4	0
7	7	A5	10	5
8	8			
9	9			
A	10			
B	11			
C	12			
D	13			
E	14			
F	15			

To set the **READER STX** press the “**UP**” or “**Down**” button until the correct setting is displayed on the LCD. Press the “**ENTER**” button.

To set the **READER ROM** press the “**UP**” or “**Down**” button until the correct setting is displayed on the LCD. Press the “**ENTER**” button.

Three site codes or user groups may be set for use by the coin box. Each site code is settable from 0 to 4095, using the “**UP**” and “**DOWN**” buttons, set the display to the desired site code.

To set the **READER Site Code 1** press the “**UP**” or “**Down**” button until the correct setting is displayed on the LCD.

Press the “**ENTER**” button.

To set the **READER Site Code 2** press the “**UP**” or “**Down**” button until the correct setting is displayed on the LCD.

If using a second site code, set this parameter as necessary, Otherwise set as 0 (Zero).

Press the “**ENTER**” button.

To set the **READER Site Code 3** press the “UP” or “Down” button until the correct setting is displayed on the LCD.

If using a third site code, set this parameter as necessary, otherwise set as 0 (Zero).

Press the “ENTER” button.

Note: Do not set any of the UN-used site codes to the same value as an active site. Example, if you are using only site 125, set READER SITE 1 to 125, make sure that READER SITE 2 and READER SITE 3 are set to 0 NOT 125!

Press the “MENU” button to Continue

Costs Mode

– Press the “ENTER” button.

To increase the **cash copy cost per price line 1** press the “UP” button. To decrease it, press the “DOWN” button.

Press the “ENTER” button.

To increase the **card copy cost per price line 1, site code 1** press the “UP” button. To decrease it, press the “DOWN” button.

Press the “ENTER” button.

To increase the **card copy cost per price line 1, site code 2** press the “UP” button. To decrease it, press the “DOWN” button.

Press the “ENTER” button.

To increase the **card copy cost per price line 1, site code 3** press the “UP” button. To decrease it, press the “DOWN” button.

Press the “ENTER” button.

To increase the **units copy cost per price line 1, site code 1** press the “UP” button. To decrease it, press the “DOWN” button.

Press the “ENTER” button.

To increase the **units copy cost per price line 1, site code 2** press the “UP” button. To decrease it, press the “DOWN” button.

Press the “ENTER” button.

To increase the **units copy cost per price line 1, site code 3** press the “UP” button. To decrease it, press the “DOWN” button.

Press the “ENTER” button.

To increase the cash copy cost per price line 2 press the “UP” button. To decrease it, press the “DOWN” button.

Press the “ENTER” button.

To increase the card copy cost per price line 2, site code 1 press the “UP” button. To decrease it, press the “DOWN” button.

Press the “ENTER” button.

To increase the card copy cost per price line 2, site code 2 press the “UP” button. To decrease it, press the “DOWN” button.

Press the “ENTER” button.

To increase the card copy cost per price line 2, site code 3 press the “UP” button. To decrease it, press the “DOWN” button.

Press the “ENTER” button.

To increase the units copy cost per price line 2, site code 1 press the “UP” button. To decrease it, press the “DOWN” button.

Press the “ENTER” button.

To increase the units copy cost per price line 2, site code 2 press the “UP” button. To decrease it, press the “DOWN” button.

Press the “ENTER” button.

To increase the units copy cost per price line 2, site code 3 press the “UP” button. To decrease it, press the “DOWN” button.

Press the “ENTER” button.

The following prices will be set only if the Interface Mode is set to “Send Fax+Copier” Refer to the Interface Mode description for details.

To increase the 1f FAX Cash Cost (First Page of a local fax), press the “UP” button. To decrease it, press the “DOWN” button.

Press the “ENTER” button.

To increase the 1a FAX Cash Cost (Additional Pages of a local fax), press the “UP” button. To decrease it, press the “DOWN” button.

Press the “ENTER” button.

To increase the 1f FAX Card Cost (First Page of a local fax), press the “UP” button. To decrease it, press the “DOWN” button.

Press the **“ENTER”** button.

To increase the **1a FAX Card Cost** (Additional Pages of a local fax), press the **“UP”** button. To decrease it, press the **“DOWN”** button.

Press the **“ENTER”** button.

To increase the **2f FAX Cash Cost** (First Page of a long distance fax), press the **“UP”** button. To decrease it, press the **“DOWN”** button.

Press the **“ENTER”** button.

To increase the **2a FAX Cash Cost** (Additional Pages of a long distance fax), press the **“UP”** button. To decrease it, press the **“DOWN”** button.

Press the **“ENTER”** button.

To increase the **2f FAX Card Cost** (First Page of a long distance fax), press the **“UP”** button. To decrease it, press the **“DOWN”** button.

Press the **“ENTER”** button.

To increase the **2a FAX Card Cost** (Additional Pages of a long distance fax), press the **“UP”** button. To decrease it, press the **“DOWN”** button.

Press the **“ENTER”** button.

To increase the **3f FAX Cash Cost** (First Page of a international fax), press the **“UP”** button. To decrease it, press the **“DOWN”** button.

Press the **“ENTER”** button.

To increase the **3a FAX Cash Cost** (Additional Pages of a international fax), press the **“UP”** button. To decrease it, press the **“DOWN”** button.

Press the **“ENTER”** button.

To increase the **3f FAX Card Cost** (First Page of a international fax), press the **“UP”** button. To decrease it, press the **“DOWN”** button.

Press the **“ENTER”** button.

To increase the **3a FAX Card Cost** (Additional Pages of a international fax), press the **“UP”** button. To decrease it, press the **“DOWN”** button.

Press the **“ENTER”** button.

Interface Mode

Press the “ENTER” button.

Ensure that the **Interface Type** is set correctly. The VS-2000 Coin Controllers may control both a fax and copy machine. To select which is to be controlled, press “UP” for copier or “DOWN” for fax.

***** THIS SHOULD BE SET TO COPIER UNLESS A SPECIAL INTERFACE IS ATTACHED FOR THE FAX FUNCTIONS *****

Press the “ENTER” button.

To increase the **Unit ID Number** press the “UP” button. To decrease it, press the “DOWN” button. The Unit ID number can be used to distinguish between different devices installed at a location.

Press the “ENTER” button.

To set the **Line 2 Mode** press the “UP” or “Down” button until the correct setting is displayed on the LCD.

This Parameter allows you to control the **Line 2 Vend Mode**. There are 3 modes of operation with descriptions below.

In the **LEVEL Mode**, the input on the second price line acts like a Shift key on a keyboard. If price **Line 2** is active before, during and after a pulse is detected on **Price 1** input, the value programmed for **Price 2** is charged.

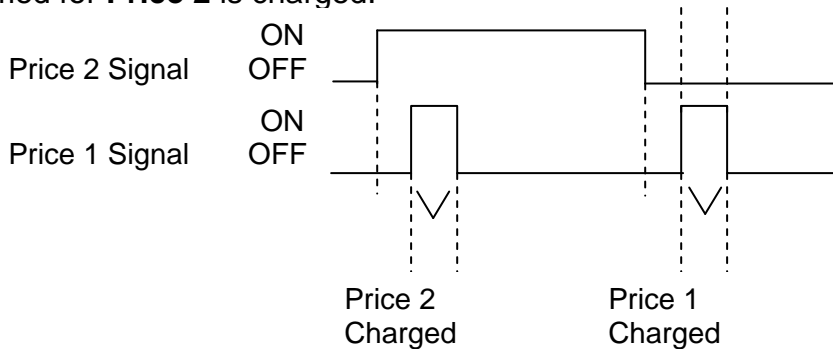

In **Pulse Mode**, **Price 2** is charged whenever a pulse is detected on the **Price 2** input.

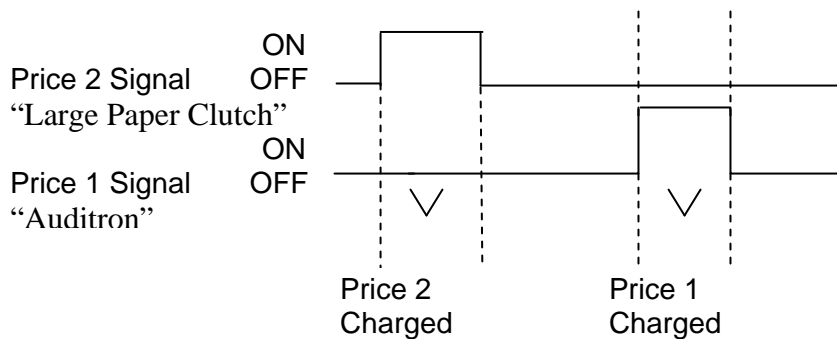

This mode would be used when individual cassette pick-up solenoids are connected to the **Price 1** and **Price 2** signal inputs.

In **Premium Mode**, **Price 2** is deducted when the **Price 2** input is activated and the **Price 1** input is ignored for the next pulse as this is for the same page.

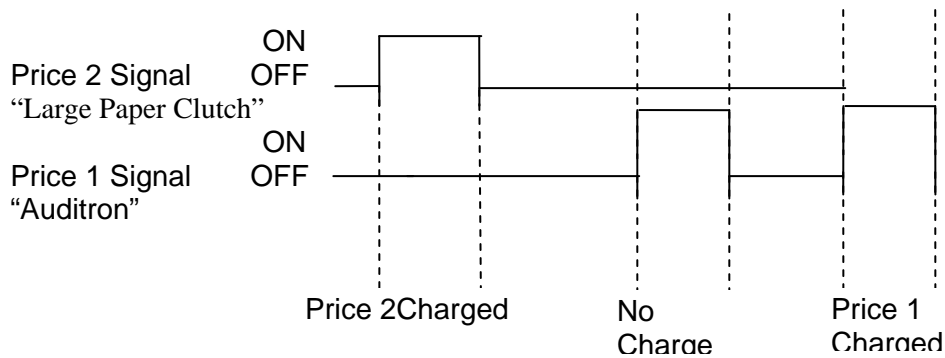

This mode would be used when **Price 1** input is connected to the Auditor Port or other common signal that will deduct for EVERY page printed. The **Price 2** input would be connected to the pick up clutch on the "Premium" paper tray.

ie. 8 ½ x 11 = \$0.10
 8 ½ x 11 R = \$0.10
 8 ½ x 14 = \$0.10
 LEDGER = \$0.15

When a ledger page is fed into the copier, a \$0.15 deduction will occur, then when the copier supplies the price 1 pulse for the same page, no deduct will result until the next page comes through. This mode is convenient when charging a premium from 1 tray only and avoids the necessity to attach the Price 1 input to all the other trays.

To increase the **Line 1 Disable Delay** of the unit press the "**UP**" button. To decrease it, press the "**DOWN**" button. This delay is used to prevent the VS-2000 from disabling mid page for Price Line 1, which can cause some copiers to jam

Press the "**ENTER**" button.

To increase the **Line 2 Disable Delay** of the unit press the "**UP**" button. To decrease it, press the "**DOWN**" button. This delay is used to prevent the VS-2000 from disabling mid page for Price Line 2, which can cause some copiers to jam

Press the "**ENTER**" button.

After a copy is made a **Return delay** should be imposed so the card is not returned before being debited. To increase the delay press "**UP**." To decrease it, press "**DOWN**."

Press the "**ENTER**" button.

To cause the VS-2000 to recognize the pulse from the copy machine it is necessary to define its width or duration. The typical length is 20msec. To increase the **Pulse Time** press "**UP**." To decrease press "**DOWN**."

Press the "**ENTER**" button.

After the VS-2000 recognizes the pulse, a **blind time** is imposed to blank out any extraneous noise or relay bounce. To increase the blind time press "**UP**." To decrease it, press "**DOWN**."

Press the “**MENU**” button to continue.

The **Disable relay Serial mode** function will control whether the enable relay is disabled when the VS-2000 begins a serial session in **Print Manager**. This setting depends upon the operation of the Multi Function Copier/Printer being controlled. Press the “**UP**” or “**Down**” button to set as required.

Press the “**ENTER**” button to continue.

The **Ignore Pulse Serial mode** function will control whether the pulses received will be counted after the VS-2000 begins a serial session in Print Manager. This setting depends upon the operation of the Multi Function Copier/Printer being controlled. Press the “**UP**” or “**Down**” button to set as required.

Press the “**ENTER**” button to continue.

The VS-2000 has an extra set of relay contacts that can be used as a reset switch to pulse switch closures across a Stop or Clear button. A special harness is required that attaches to pins 1 and 2 of **J4** on the VS-2000 Main CPU board. Please contact Boscop, Inc. if this function is desired to obtain proper cabling.

The **L3=Clear copier mode** can be used to stop the copy process by pulsing a relay closure across the STOP or CLEAR button on the copier being controlled when the Card/Coin return button is pressed. Press the “**UP**” or “**Down**” button to set for Yes or No.

Press the “**ENTER**” button to continue.

If using the **Clear Copier Mode**, the **L3 Number of Pulses** is set to control the number of reset pulses the Stop Clear button receives Press the “**UP**” or “**Down**” button to set as required.

Press the “**ENTER**” button to continue.

If using the Clear Copier Mode the **L3 Pulse on time** is set to control the time in milliseconds that the reset Stop Clear button is held closed for each pulse. Press the “**UP**” or “**Down**” button to set as required.

Press the “**ENTER**” button to continue.

If using the Clear Copier Mode the **L3 Pulse off time** is set to control the time in milliseconds that the reset Stop Clear button is held open between each pulse. Press the “**UP**” or “**Down**” button to set as required.

Press the “**MENU**” button to continue.

Bonus Mode

The Bonus function can be used to encourage patrons to add larger values to the cash card by offering a “bonus” percentage on monies added to the card. There are 3 levels of bonus available based upon the value of money being added. **NOTE:** The bonus is determined by the Value added to the card during the session NOT the balance on the card

Press the “**ENTER**” button.

Press the “**UP**” or “**Down**” button to set **Use Bonuses** to “**Yes**” or “**No**”.

Press the “**ENTER**” button.

If using the Bonus Mode **Bonus Level 1** is set to determine at what value of cash inserted the Level 1 bonus percentage will apply. Press the “**UP**” or “**Down**” button to set as required.

Press the “**ENTER**” button.

If using the Bonus Mode **Bonus 1 % to add** is set to determine the amount of bonus as a percent of the cash inserted for level 1 bonus. Press the “**UP**” or “**Down**” button to set as required.

Press the “**ENTER**” button.

If using the Bonus Mode **Bonus Level 2** is set to determine at what value of cash inserted the Level 2 bonus percentage will apply. Press the “**UP**” or “**Down**” button to set as required.

Press the “**ENTER**” button.

If using the Bonus Mode **Bonus 2 % to add** is set to determine the amount of bonus as a percent of the cash inserted for Level 2 bonus. Press the “**UP**” or “**Down**” button to set as required.

Press the “**ENTER**” button.

If using the Bonus Mode **Bonus Level 3** is set to determine at what value of cash inserted the level 3 bonus percentage will apply. Press the “**UP**” or “**Down**” button to set as required.

Press the “**ENTER**” button.

If using the Bonus Mode **Bonus 3 % to add** is set to determine the amount of bonus as a percent of the cash inserted for level 3 bonus. Press the “**UP**” or “**Down**” button to set as required.

Press the “**ENTER**” button.

Turn the bypass key back to the **OFF** position and remove it.

Set PDA Password

This Mode should not be used unless a keypad is attached to the main board to enter a new password for access by the PDA for settings and meters collection. If this mode is invoked accidentally; reset the VS-2000 by removing then restoring the power.

Turn the bypass key back to the **OFF** position and remove it.

READ METERS

To read the meters the "BYPASS KEY" must be off. Press the "MENU" button.
The display will indicate **.25 .10 .05**

XXX XXX XXX showing the current coin tube levels.

Press the "**MENU**" button again to view the re-settable meters.

Press the "**ENTER**" button to View the Meters. Press the "**UP**" button to print. **

Press the "**MENU**" button again to view the Hard (non-re-settable) meters.

Press the "**ENTER**" button to View the Meters. Press the "**UP**" button to print.**

** Refer to "**Printing The Meters**" for printer details:

The display will indicate this first meter reading.

To clear this meter reading and each of the others hold the "**DOWN**" and press the "**UP**" button simultaneously as each meter reading is displayed. After each meter is displayed and or cleared press the "**ENTER**" button to scroll to the next meter reading. Pressing the "**MENU**" button at any time will exit the current mode.

**NOTE: ONLY METERS RELATING TO INSTALLED COMPONENTS WILL BE DISPLAYED.
I.E. A 5210 will not show Bill or Card meters.**

Meter Name**Explanation**

User Coin In XXX.XX:	This is the amount of coins inserted by users.
User Coin Out XXX.XX:	This is the amount of change returned to users.
Coin box XXX.XX:	This is the amount of coins in the coin box.
Bypass Coin in XXX.XX:	This is the value of coins added in Bypass mode
Unused Escrow XXX.XX:	This is the value of coins unused (held in escrow)
User Bill In XXX.XX:	This is the total value of bills inserted. *
\$1 Bill in XXXXX:	This is the total number of \$1 bills*
\$2 Bill in XXXXX:	This is the total number of \$2 bills*
\$5 Bill in XXXXX:	This is the total number of \$5 bills*
\$10 Bill in XXXXX:	This is the total number of \$10 bills*

\$20 Bill in XXXXX:	This is the total number of \$20 bills*
Card in Site 1 XX.XXX	This is the total value deducted from site 1 cards.
Card in Site 2 XX.XXX	This is the total value deducted from site 2 cards.
Card in Site 3 XX.XXX	This is the total value deducted from site 3 cards.
Cash Add to Card XXX.XX:	This is the total Cash value added to cards
Unit Add to Card XXX	This is the total Units value added to cards
Bonus to Card XXX.XX:	This is the Bonus value added to cards
L1 Bypass Copies XXX:	This is the total number of Bypass Copies per price line 1
L2 Bypass Copies XXX:	This is the total number of Bypass Copies per price line 2
L1 Cash Copies XXX:	This is the number of Cash Copies per price line 1
L2 Cash Copies XXX:	This is the number of Cash Copies per price line 2
L1 Card Copies 1 XXX:	This is the number of Card Copies per price line 1 Site code 1
L1 Card Copies 2 XXX:	This is the number of Card Copies per price line 1 Site code 2
L1 Card Copies 3 XXX:	This is the number of Card Copies per price line 1 Site code 3
L2 Card Copies 1 XXX:	This is the number of Card Copies per price line 2 Site code 1
L2 Card Copies 2 XXX:	This is the number of Card Copies per price line 2 Site code 2
L2 Card Copies 3 XXX:	This is the number of Card Copies per price line 2 Site code 3
L1 Unit Copies XXX:	This is the total number of Unit Copies per price line 1
L2 Unit Copies XXX:	This is the total number of Unit Copies per price line 2
Danyl Value Convert	This is the total value of money converted from Danyl format to ITC Format. (This meter only applies if feature enabled)
Danyl number Convert	This is the total number of cards converted from Danyl format to ITC Format. (This meter only applies if feature enabled)
Note: the following Fax meters only apply if the Interface selected is “Send Fax+Copier”	
Fp Local Fax Byp	This is First Pages of Local Fax’s sent in Bypass.
Fp Long Fax Byp	This is First Pages of Long Distance Fax’s sent in Bypass.
Fp Int’l Fax Byp	This is First Pages of International Fax’s sent in Bypass.

Fp Local Fax Cash	This is First ²¹ Pages of Local Fax's sent with Cash.
Fp Long Fax Cash	This is First Pages of Long Distance Fax's sent with Cash.
Fp Int'l Fax Cash	This is First Pages of International Fax's sent with Cash.
Fp Local Fax Crd	This is First Pages of Local Fax's sent with cards.
Fp Long Fax Crd	This is First Pages of Long Distance Fax's sent with cards.
Fp Int'l Fax Crd	This is First Pages of International Fax's sent with cards.
Ap Local Fax Byp	This is Additional Pages of Local Fax's sent in Bypass.
Ap Long Fax Byp	This is Additional Pages of Long Distance Fax's sent in Bypass.
Ap Int'l Fax Byp	This is Additional Pages of International Fax's sent in Bypass.
Ap Local Fax Cash	This is Additional Pages of Local Fax's sent with Cash.
Ap Long Fax Cash	This is Additional Pages of Long Distance Fax's sent with Cash.
Ap Int'l Fax Cash	This is Additional Pages of International Fax's sent with Cash.
Ap Local Fax Crd	This is Additional Pages of Local Fax's sent with cards.
Ap Long Fax Crd	This is Additional Pages of Long Distance Fax's sent with cards.
Ap Int'l Fax Crd	This is Additional Pages of International Fax's sent with cards.

Press the "**MENU**" button. The display will indicate **Hard Meters**. The **Hard Meters** are grand totals and are not re-settable. The meters indicated by * are not included in the **Hard Meters**.

Press the "**MENU**" button to return to Idle mode.

Printing the Meters

To print the meters or capture them with a serial device, attach the peripheral via the appropriate cable to **Com 2** on the coin box. Assure that the peripheral is **“ONLINE”** and ready to accept data/

With the bypass key in the **OFF** position Press the **“MENU”** button.

The display will indicate **.25 .10 .05**
XXX XXX XXX showing the current coin tube levels.

Press the **“MENU”** button again for the re-settable meters. Press the **“UP”** button to print.

OR

Press the **“MENU”** button again for the Hard (non-re-settable) meters. Press the **“UP”** button to print.

The Serial Data will be transmitted at 9600 Baud with No Parity, 8 Data bits and 1 stop bit. Refer to the diagrams below describing the cables and printer settings.

Printer Cable

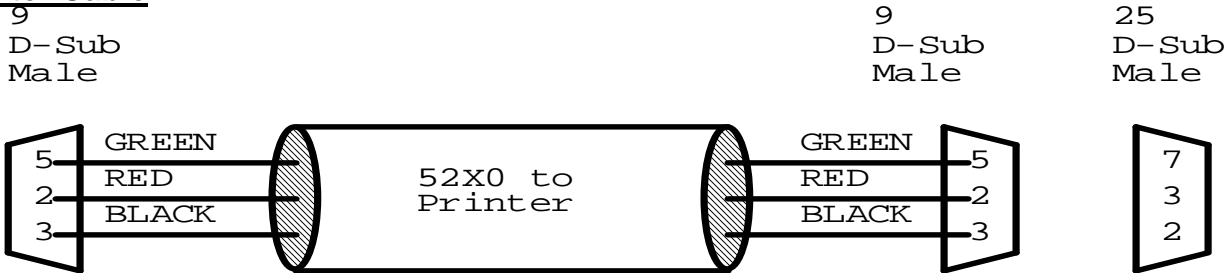

Seiko DPU 414 Printer Settings

Dip SW-1		Dip SW-2		Dip SW-3	
1 (OFF)	Input = Serial	1 (OFF)	Printing Col. = 80	1 (ON)	Data Length = 8 Bits
2 (ON)	Print Speed = High	2 (ON)	User Font = On	2 (ON)	Parity Setting = NO
3 (OFF)	Auto Loading = Off	3 (OFF)	Character Select = Special	3 (ON)	Parity Condition = Odd
4 (OFF)	Auto LF = Off	4 (OFF)	Zero = Slash	4 (OFF)	Busy Control = Xon/Xoff
5 (ON)	SettingCommand = Enable	5 (ON)	International	5 (OFF)	Baud
6 (OFF)	Printing	6 (ON)	Character	6 (ON)	Rate
7 (ON)	Density	7 (ON)	Set	7 (ON)	Select
8 (ON)	= 100%	8 (OFF)	= U.S.A.	8 (ON)	= 9600bps

PC Cable

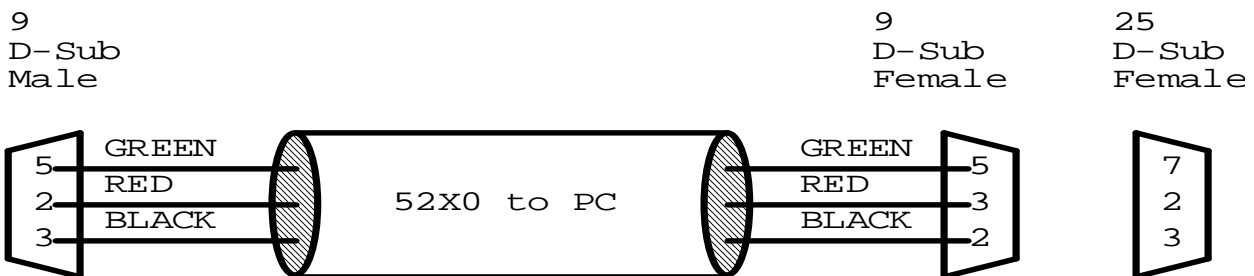

Sample Reports From Serial Port

**NOTE: ONLY METERS RELATING TO INSTALLED COMPONENTS WILL BE OUTPUT.
I.E. A5210 will not send bill or card meters**

BOSCOPI		BOSCOPI	
Model M52X0		Model M52X0	
Transaction Log For Unit ID #0001		Transaction Log For Unit ID #0001	
RESETTABLE Meters		NON_RESETTABLE Meters	
User Coin In	\$ 0.00	User Coin In	\$ 0.00
User Coin Out	\$ 0.00	User Coin Out	\$ 0.00
Coin Box	\$ 0.00	Coin Box	\$ 0.00
Bypass Coin In	\$ 0.00	Bypass Coin In	\$ 0.00
Unused Escrow	\$ 0.000	Unused Escrow	\$ 0.000
L1 Bypass Copies	00000	L1 Bypass Copies	00000
L2 Bypass Copies	00000	L2 Bypass Copies	00000
L1 Cash Copies	00000	L1 Cash Copies	00000
L2 Cash Copies	00000	L2 Cash Copies	00000
Fp Local Fax Csh	00000	Fp Local Fax Csh	00000
Fp Long Fax Csh	00000	Fp Long Fax Csh	00000
Fp Int'l Fax Csh	00000	Fp Int'l Fax Csh	00000
Ap Local Fax Csh	00000	Ap Local Fax Csh	00000
Ap Long Fax Csh	00000	Ap Long Fax Csh	00000
Ap Int'l Fax Csh	00000	Ap Int'l Fax Csh	00000
Card In Site 1	\$ 0.000	Card In Site 1	\$ 0.000
Card In Site 2	\$ 0.000	Card In Site 2	\$ 0.000
Card In Site 3	\$ 0.000	Card In Site 3	\$ 0.000
Cash Add To Card	\$ 0.000	Cash Add To Card	\$ 0.000
Unit Add To Card	\$ 0.000	Unit Add To Card	\$ 0.000
Bonus To Card	\$ 0.000	Bonus To Card	\$ 0.000
L1 Card Copies 1	00000	L1 Card Copies 1	00000
L1 Card Copies 2	00000	L1 Card Copies 2	00000
L1 Card Copies 3	00000	L1 Card Copies 3	00000
L2 Card Copies 1	00000	L2 Card Copies 1	00000
L2 Card Copies 2	00000	L2 Card Copies 2	00000
L2 Card Copies 3	00000	L2 Card Copies 3	00000
L1 Units Copies	00000	L1 Units Copies	00000
L2 Units Copies	00000	L2 Units Copies	00000
Danyl Value Conv \$	0.000	Danyl Value Conv \$	0.000
Danyl Num Conv	00000	Danyl Num Conv	00000
Fp Local Fax Crd	00000	Fp Local Fax Crd	00000
Fp Long Fax Crd	00000	Fp Long Fax Crd	00000
Fp Int'l Fax Crd	00000	Fp Int'l Fax Crd	00000
Ap Local Fax Crd	00000	Ap Local Fax Crd	00000
Ap Long Fax Crd	00000	Ap Long Fax Crd	00000
Ap Int'l Fax Crd	00000	Ap Int'l Fax Crd	00000
User Bill In	\$ 0.00	User Bill In	\$ 0.00
\$1 Bills In	00000		
\$2 Bills In	00000		
\$5 Bills In	00000		
\$10 Bills In	00000		
\$20 Bills In	00000		

NOTE: The Fax meters will only be produced if the interface selected is "Send Fax+Copier".

INSTALLATION

Most photocopiers provide connection through a "Key Counter" or "Auditron" harness. The coin box enables the copier through the **ENABLE** Circuit of by closing a switch when sufficient credit is available. A voltage signal or relay contact closure signals the coin box that a copy has been produced through the **PULSE** circuit. If the copier does not have this circuitry available please contact Boscop, Inc. Service department for other options.

Placement of the Coin, Bill and Card Controller

The Coin box is designed to be mounted on or near the copier to be controlled. Different mounting brackets or stands can be provided by Boscop, Inc. as an option. Mounting holes are located on the back (door) of the housing to secure it to the surface on which it is placed, i.e. adjacent wall or to the machine. The coin box should always be attached in a proper way for safety and security.

Connecting to Power

Power is supplied to the controller by plugging the external Class 2, 24VAC transformer into a standard grounded 120 Volt wall outlet. The use of long extension cords or power bars is not recommended.

Connection to the Copier

Enable:

The **Enable** is provided on the **Black and White** wires from the coin-op. This is a dry relay contact which is NORMALLY OPEN (open when disabled, closed when enabled).

The relay is capable of switching ½ Amp at 60 Volts AC or DC. Typically, the **Enable** is attached to the copier key counter plug by removing any jumper on the plug then attaching the **Black** wire to one side of the circuit and the **White** to the other side.

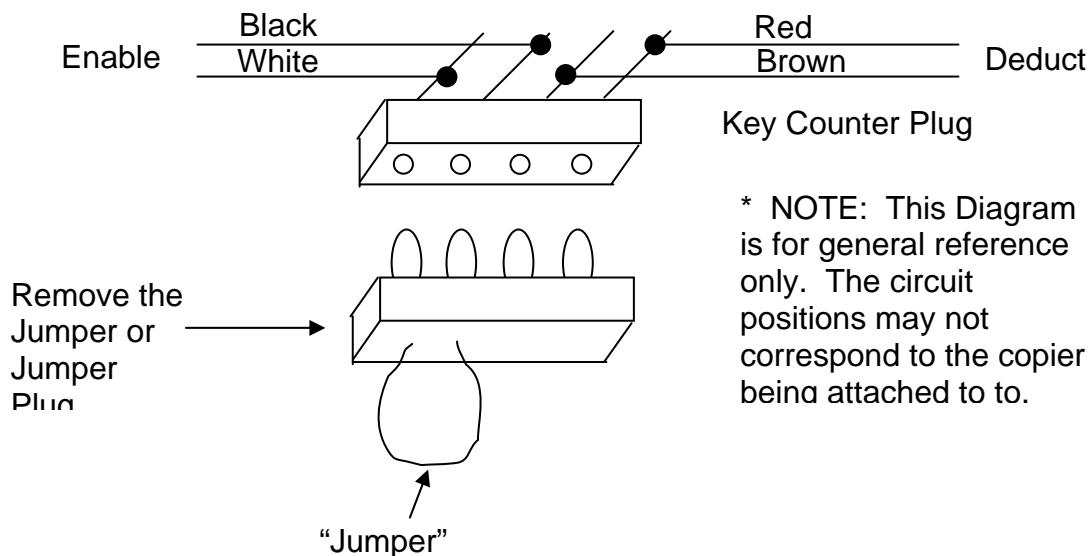

Pulse:

The pulse is typically connected to the other 2 circuits on the key counter plug. On most copiers, this will give 1 count per page printed (24vdc Pulse).

Connect the **Red** to one wire of the Deduct circuit and the **Brown** to the other.

Chassis Ground

The **Green Wire** from the coin op is attached to the ground and the case of the coin op. The **Green** should be attached to the copiers chassis to ensure that both units are properly grounded for safety and to discharge potentially damaging Static Electricity away from the electronics in the Coin box.

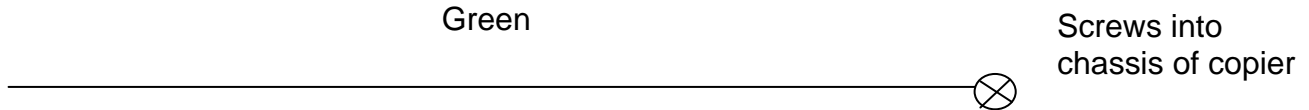

Special Considerations:

Using a Paper Clutch

On some copiers, the Deduct Pulse comes very late in the print cycle which may allow additional pages to be printed even though the credit is used up. To get around this, a common clutch (registration clutch for example) can be used for the billing pulse. Attach the **Red** wire to one side of the clutch and the **Brown** to the other.

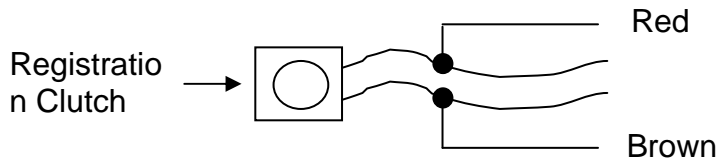

The Deduct Pulse may also be taken off of the pick-up clutches for each tray using blocking diode as follows:

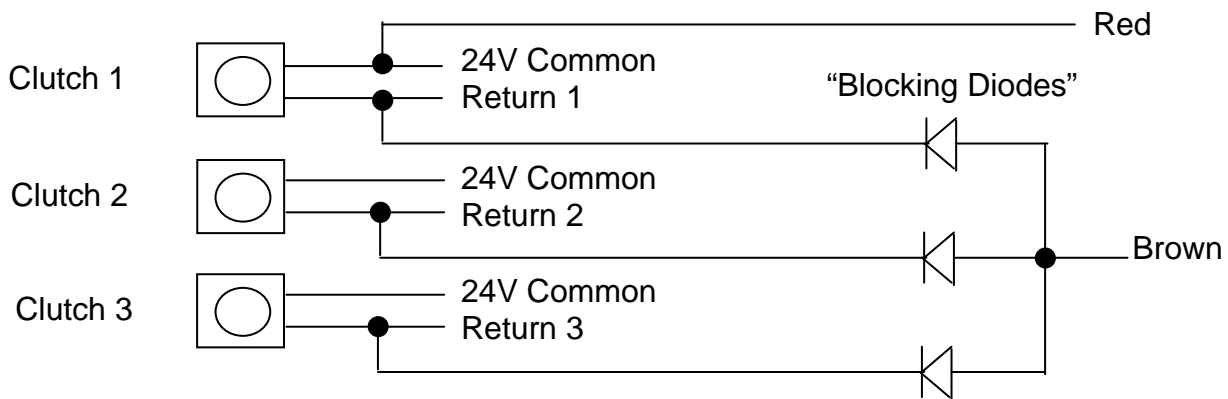

Note: —|>— Denotes diodes required (not supplied) (i.e. 1N4003 or equivalent). Diodes MUST be used to isolate the clutches, otherwise permanent damage may occur to the copier

Second Price (i.e. Large Paper) Connection:

-“Line 2 LEVEL Mode”

The **Yellow and Violet** wires on the interface plug are available to act as a “**Shift to Price 2**” input. When a voltage between 5 and 30 volts (AC or DC) is applied to this input, the coin-op will reflect the number of copies available to the second price set in the parameters. Any Deduct Pulse received while this signal is active will change the second Price setting. Typically, the “**Shift to Price 2**” input is attached to an LED indicator that is lit when the larger paper cassette is being used.

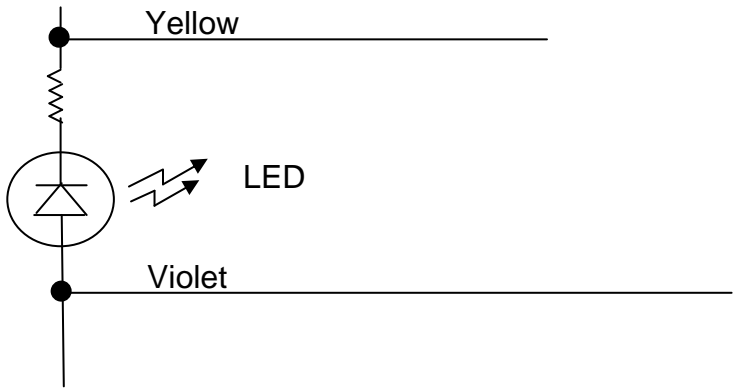

Second Price (i.e. Large Paper) Connection:

-“Line 2 PULSE Mode”

The **Price 1** input is attached to each clutch to charge **Price 1**. The **Price 2** input is attached to each clutch to charge **Price 2**.

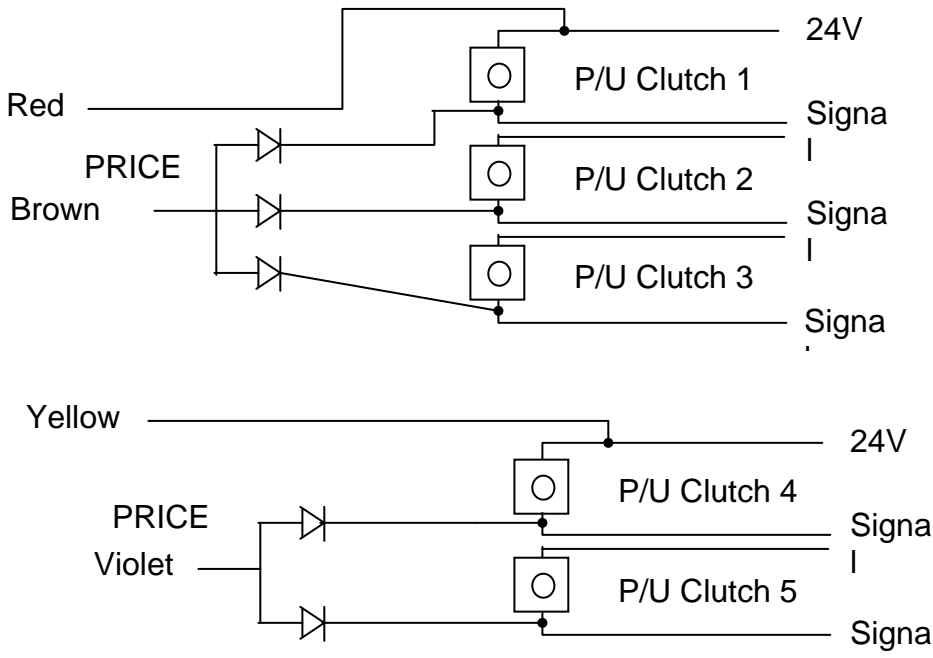



Note:  Denotes diodes required (not supplied) (i.e. 1N4003 or equivalent). Diodes MUST be used to isolate the clutches, otherwise permanent damage may occur to the copier.

Second Price (i.e. Large Paper) Connection:

-“Line 2 PREMIUM Mode”

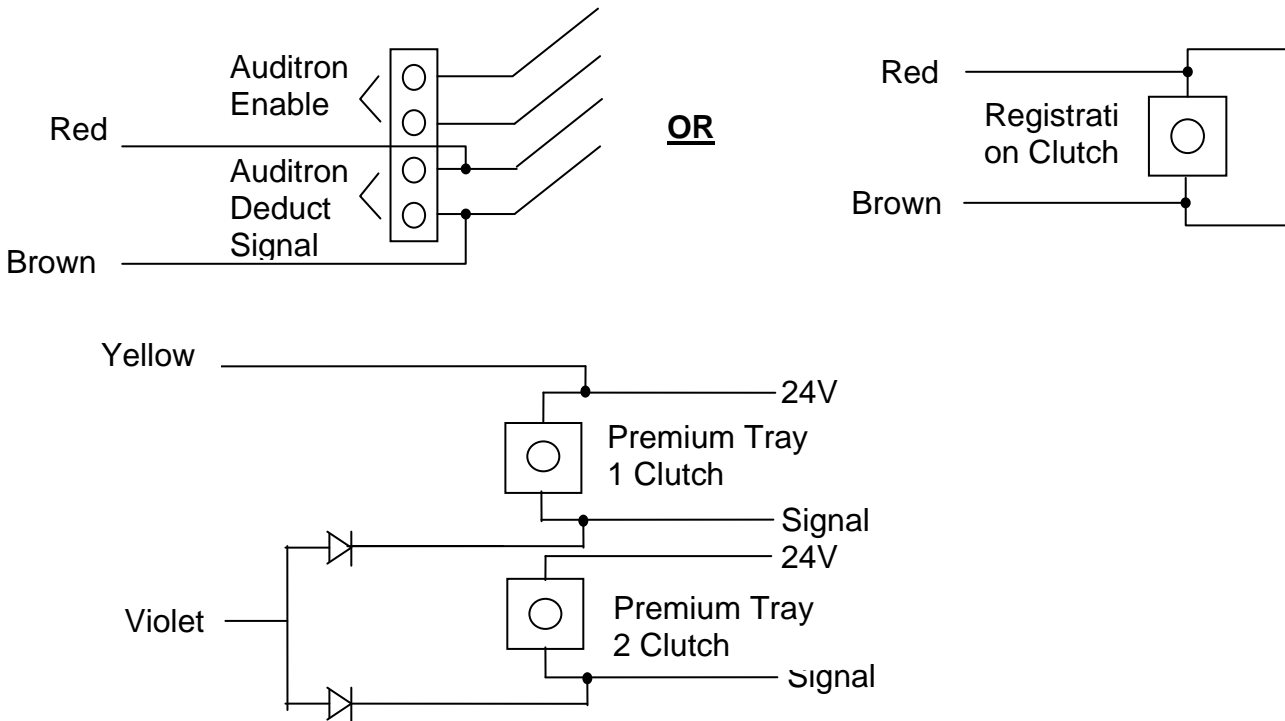
The **Price 1** input is attached to a common clutch (i.e. registration clutch) or signal (i.e. the Auditor or key counter port). The **Price 2** input is attached to the paper tray clutch(es) that are to charge the **Price 2** amount. **Note: In this mode, when premium pages are printed, the Price 1 pulse immediately following the Price 2 pulse is ignored.**



Note:  Denotes diodes required (not supplied) (i.e. 1N4003 or equivalent). Diodes **MUST** be used to isolate the clutches, otherwise permanent damage may occur to the copier.

WARRANTY AND LIABILITY CONTRACT

By issuing a Purchase Order or contracting with Boscop Inc to carry out the supply of products, clients are accepting the terms of this Warranty and Liability Contract.

This document states the warranty and liability offered by Boscop Inc. on any products we manufacture or services we provide for our clients.

Boscop Inc. shall not be liable for any direct, indirect and/or consequential damages or losses, including loss of use, revenue, profit incurred by the client, its customers and/or any third party as a result of the use of the work carried out by Boscop Inc. for the client, including any loss resulting from equipment failure or malfunctions, design or programming errors or any other use of the work carried out in this contract. The client specifically waives any claim or recourse it may have against Accountor Systems in any of the above instances.

When Boscop Inc. is manufacturing equipment, the equipment to be manufactured will be an exact replication of previously manufactured product, or the prototype, unless specified otherwise by the client, in writing.

Boscop Inc. warrants all parts of new equipment for one year, from date of invoice or if warranty card is on file, from date on card, against DEFECTIVE MATERIAL OR WORKMANSHIP, but not against damage caused by accident, abuse, faulty installation, or improper operation.

Boscop inc. will repair, or at its option, replace without charge, F.O.B. factory, defective parts returned to its factory, transportation charges prepaid. Boscop Inc. obligation under this warranty is limited to repair or replacement as stated herein and does not include the return shipping charges.

Any changes in design or improvements added to the line of equipment shall not create any obligation to install same on equipment previously sold and delivered to the client.

Any unauthorized alteration of, or addition to, articles of the contractors manufacture voids this warranty.

Equipment returned for Warranty repair must be accompanied by a copy of the Bill of Sale as verification of Purchase date. Equipment returned without a Bill of Sale will be charged to the customer at the normal repair rates.

**Bosocp, Inc.
159 Dana Hill Road
New Hampton, NH 03256
Phone: 603-744-2188
Fax: 603-744-2062
Web Site:www.boscop.com**