

Boscop Inc.

INSTALLATION AND SET UP MANUAL

BC201E Card Encoder Mini Till



**Boscop Inc.
159 Dana Hill Rd
New Hampton NH 03256
Phone: 603-744-2188
Fax: 603-744-2062
email: service@boscop.com**

Table of Contents

1. Sales and Services	3
2. Command Cards Required	3
3. Setting Dip Switches	3 - 5
4. Parameter Setting	5
5. Encoding Cards	6
6. Auto Encode Function	6
7. Operation	7
8. Read Meters	7 - 13
9. Clearing Meters	13
10. Error Code Summary	13
11. Using an Optional Printer	14
12. Capturing 1035 Meter Readings With Hyper-Terminal	15 - 16
13. Frequently Asked Questions	17
14. Explanation Of Terms Used In Service	17 - 20
15. Warranty	20

1. SALES AND SERVICES

At Boscop Inc., complete customer satisfaction is our number one goal. As such, customer support is readily available to satisfy any need you may have. Whether it's sales information, a service requirement or just general inquiry, you can call Boscop Inc. at 800-229-8765.

SALES

If you are a new or existing customer with a new installation in mind, our highly qualified sales staff can custom tailor a product solution for "your" particular needs.

SERVICE

If you require technical assistance advice or parts please contact our service department at 1-603-744-2188.

INTRODUCTION

The Model 1035 Mini Till is designed to add and subtract value from cash and unit cards. The 1035 also has the ability to encode new cards. The 1035 is also designed to print a transaction receipt through an optional serial printer. See the section in this manual on printer use for details.

2. COMMAND CARDS REQUIRED

1. PARAMETER SETUP
2. CLEAR METERS
3. READ METERS
4. ENCODE CASH CARD - (Used to format CASH cards)
5. ENCODE UNIT CARD - (Used to format UNIT cards)
6. OPERATOR LOG-IN cards for operators 1 through 5.

3. SETTING THE DIP SWITCHES

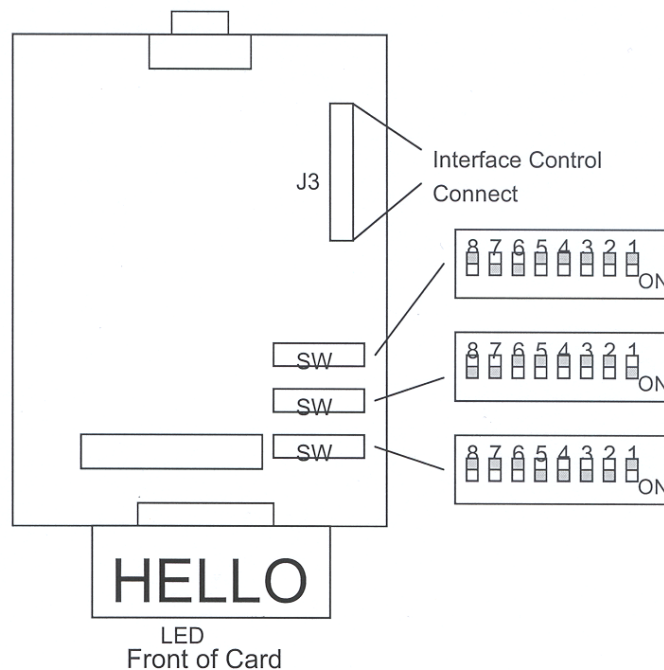

NOTE: SW 2 shown set for C1A ROM Code.

1. Unplug the power supply from the wall outlet.
2. Unplug the Keypad connector at the back of the Till.
3. To access the switches insert the key in the back of the reader and turn it 180 degrees which will unlock the transport from the cover.
4. Remove the transport by pushing the black front bezel where the card would be inserted at the front of the reader. Once the bezel has cleared the face plate on the cover, slide the transport completely out.
5. The switches are located on the board on top of the transport.
6. Set the switches according to your site requirements as follows:

DIP SWITCH SETTINGS

BANK 'A'	SW 1	* OFF - Allow Old Format ON - Reject Old Format
	SW 2	OFF - Not used ON - Not used
	SW 3	OFF - Not Used ON - Not Used
	SW 4	OFF - Not used ON - Not used
	SW 5	OFF - Do not use SENSOR 3 * ON - Use SENSOR 3
	SW 6	* OFF - Do not allow COMMAND CARDS ON - Allow COMMAND CARDS
	SW 7	* OFF - Do not perform TEST ON - Perform TEST + Diagnostic Data on Printout
	SW 8	* OFF - Do not CONVERT code ON - CONVERT code

*Preferred switch settings for normal operation.

BANK 'B' SW 1-4 "ROM CODE" see Rom Code Settings on next page or contact Boscop support.

SW 5-8 "START BYTE" see Rom Code Settings on next page or contact Boscop support.

BANK 'C'	SW 1-4	"ROM for XCP systems,
	SW 5	OFF - TOGGLE "HELLO" ON - STATIONARY "HELLO"
	SW 6	OFF - Hold Flagged Card ON - Do not Hold Flagged Card
	SW 7	OFF - Not Used ON - Not Used
	SW 8	OFF - Not used ON - Not used

ROM Code Settings

The following table shows the settings to be used on Switch Bank 2 for common ROM codes. If you cannot locate your ROM Code or have any questions, contact Boscop support 1-603-744-2188

CODE	SWITCH	1	2	3	4	5	6	7	8
40A		Off	Off	Off	Off	Off	Off	On	Off
C0A		Off	Off	Off	Off	Off	Off	On	On
C1A		On	Off	Off	Off	Off	Off	On	On
B9A		On	Off	Off	On	On	On	Off	On

4. PARAMETER SETTING

Outlined below is a list of instructions on how to set the Mini Transaction Till's parameters.

NOTE: Switch #6 of Bank SW1 must be in the ON position to use this Command Card. See Section 7 for details.

1. Insert the "Set Parameters" Card with the label face up.
2. The reader will take the card and the display will show "Pr.SET".
3. Remove the card from the reader.
4. The Mini Transaction Till's display will flash between "i.d" and a "value". Where the "i.d" is the Machine Identification and the "value" is what it is set to.
5. To change this number to zero, press and hold the black card eject button. Insert the card until it stops, then release the button and remove the card.
6. To increase the value of the number press and hold the black card eject button until the desired value is obtained. The button may be pressed and released as many times as required to achieve the desired value. If you exceed the number the process will have to be repeated from Step 5.
7. In order to advance to the next parameter, quickly insert and remove the "Set Parameters" card and the next parameter will appear on the display.
8. Repeat this process until all the parameters are set properly.
9. Parameter set-up listing:
 - i.d. = ID of Encoder (0-65355)
 - tEntH.d = Display tenth of a cent (YES)
= Don't display tenth of a cent (NO)
 - HOLd = Hold card if bad (YES)
= Don't hold card if bad (NO)
 - OPEr 1 = Enable Operator 1 (YES)
= Disable Operator 1 (NO)
 - OPEr 2 = Enable Operator 2 (YES)
= Disable Operator 2 (NO)
 - OPEr 3 = Enable Operator 3 (YES)
= Disable Operator 3 (NO)
 - OPEr 4 = Enable Operator 4 (YES)
= Disable Operator 4 (NO)
 - OPEr 5 = Enable Operator 5 (YES)
= Disable Operator 5 (NO)
 - Op.1..Add = Operator 1 user allowed to add (YES)
= Operator 1 user not allowed to add (NO)

- Op.2..Add = Operator 2 user allowed to add (YES)
= Operator 2 user not allowed to add (NO)
 - Op.3..Add = Operator 3 user allowed to add (YES)
= Operator 3 user not allowed to add (NO)
 - Op.4..Add = Operator 4 user allowed to add (YES)
= Operator 4 user not allowed to add (NO)
 - Op.5..Add = Operator 5 user allowed to add (YES)
= Operator 5 user not allowed to add (NO)
 - Op.#.Sub = Operator # user allowed to subtract (YES)
= Operator # user not allowed to subtract (NO)
 - Printer = Printer Communication Settings
The first two digits indicate Baud rate: 12=1200, 96=9600
The third digit indicates parity: N=no parity, O=odd parity, E=even parity.
The fourth digit indicates the # of data bits.
the last digit indicates the # of stop bits.
ie : 12 n.8.1 =1200 Baud, No Parity, 8 Data bits, 1 Stop bit
 - Site A = Your unique Site Code 1
 - Site B = Your unique Site Code 2 set to 0 (zero) if not used
 - Site C = Your unique Site Code 3 set to 0 (zero) if not used
10. Step through all the parameters by inserting and removing the card until you return to “HELLO” or “LOG-In” on the display.

5. ENCODING CARDS

1. Log in with a valid Operator Card at the prompt “LOG-In”.
2. For encode operation insert the "ENCODE CASH" or “ENCODE UNITS” card. The display will indicate “CASH” or “UNITS”, then the value of the amount to encode.
3. To increase the value to encode, press and release the push button until the value you want to encode is displayed.
4. If you want a lower value than is currently displayed, press and hold in the push button, insert the card until it stops, release the button., then remove the card to return to 00.00.
5. Again, use the push button to set the value you wish to encode.
6. Insert as many blank cards as you desire to encode.

6. AUTO ENCODE FUNCTION

This device has been designed to automatically format NEW (never been encoded) cards. If a blank, unformatted card is inserted into the Reader for the first time, it will be encoded with zero dollars (0.00) to Site Code A, then come back out with the display showing CASH0. The card can now be re-inserted and will display 0.00 allowing you to add value to it through the keypad if an operator is logged in.

Note: This function only works with NEW UNFORMATTED cards. Any previously formatted or errored cards must be manually re-encoded with the Encode Cash or Encode Units Control Cards. See Section 3 for details.

7. OPERATION

The unit will not add or subtract value from a card until an operator "LOG-IN" card has been inserted. (Operator 1 through 5)

1. At the Log-in prompt, insert an Operator card. The Till will briefly display **L# IN** and return card. (# - Operator card used)
2. Insert a previously formatted value card at the "HELLO" prompt.
3. You may now add or subtract value from the card using the Keypad.
 - i) First Enter the desired value to be added or subtracted.
 - ii) Press the key indicating the desired operation "ADD" or "SUB".
 - iii) Press Enter to complete the transaction.

NOTE: If the Front Push Button is pressed before the ENT key the transaction will be voided and the card will be returned with the original value. If an incorrect entry is made, pressing the "CLR" key will return the original value of the card.

4. To "Log Off", reinsert the same Operator Card. This returns the Till to its idle state (display prompts "LOG-IN").

NOTE: To change operators, it is not necessary to log out the previous operator, just insert the new operator's card to log in the new operator.

8. READ METERS

Insert the READ METERS card to cause the meters to be displayed. To step to the next meter, insert the card again until it stops and then remove it. To jump out of the Read Meters routine, press the Front Push Button front button.

The following is a list of meters with their appropriate title:

IMPORTANT NOTE: References to "Cash or Units value added..." Reflect the value added PLUS value encoded for that category.

C.A.01.SA	=	Cash added to site A cards by operator 1.
C.S.01.SA	=	Cash subtracted from site A cards by operator 1.
C.A.01.Sb	=	Cash added to site b cards by operator 1.
C.S.01.Sb	=	Cash subtracted from site b cards by operator 1.
C.A.01.SC	=	Cash added to site C cards by operator 1.
C.S.01.SC	=	Cash subtracted from site C cards by operator 1.
C.E.01.SA	=	Cash encoded to site A cards by operator 1.
C.E.01.Sb	=	Cash encoded to site B cards by operator 1.
C.E.01.SC	=	Cash encoded to site C cards by operator 1.
U.A.01.SA	=	Units added to site A Cards by operator 1.
U.S.01.SA	=	Units Subtracted from site A Cards by operator 1.
U.A.01.Sb	=	Units added to site b Cards by operator 1.
U.S.01.Sb	=	Units Subtracted from site b Cards by operator 1.
U.A.01.SC	=	Units added to site C Cards by operator 1.
U.S.01.SC	=	Units Subtracted from site A Cards by operator 1.
U.E.01.SA	=	Units Encoded to site A cards by operator 1.

U.E.01.Sb	=	Units Encoded to site B cards by operator 1.
U.E.01.SC	=	Units Encoded to site C cards by operator 1.
C.A.02.SA	=	Cash added to site A cards by operator 2.
C.S.02.SA	=	Cash subtracted from site A cards by operator 2.
C.A.02.Sb	=	Cash added to site b cards by operator 2.
C.S.02.Sb	=	Cash subtracted from site b cards by operator 2.
C.A.02.SC	=	Cash added to site C cards by operator 2.
C.S.02.SC	=	Cash subtracted from site C cards by operator 2.
C.E.02.SA	=	Cash encoded to site A cards by operator 2.
C.E.02.Sb	=	Cash encoded to site B cards by operator 2.
C.E.02.SC	=	Cash encoded to site C cards by operator 2.
U.A.02.SA	=	Units added to site A Cards by operator 2.
U.S.02.SA	=	Units Subtracted from site A Cards by operator 2.
U.A.02.Sb	=	Units added to site b Cards by operator 2.
U.S.02.Sb	=	Units Subtracted from site b Cards by operator 2.
U.A.02.SC	=	Units added to site C Cards by operator 2.
U.S.02.SC	=	Units Subtracted from site A Cards by operator 2.
U.E.02.SA	=	Units Encoded to site A cards by operator 2.
U.E.02.Sb	=	Units Encoded to site B cards by operator 2.
U.E.02.SC	=	Units Encoded to site C cards by operator 2.
C.A.03.SA	=	Cash added to site A cards by operator 3.
C.S.03.SA	=	Cash subtracted from site A cards by operator 3.
C.A.03.Sb	=	Cash added to site b cards by operator 3.
C.S.03.Sb	=	Cash subtracted from site b cards by operator 3.
C.A.03.SC	=	Cash added to site C cards by operator 3.
C.S.03.SC	=	Cash subtracted from site C cards by operator 3.
C.E.03.SA	=	Cash encoded to site A cards by operator 3.
C.E.03.Sb	=	Cash encoded to site B cards by operator 3.
C.E.03.SC	=	Cash encoded to site C cards by operator 3.
U.A.03.SA	=	Units added to site A Cards by operator 3.
U.S.03.SA	=	Units Subtracted from site A Cards by operator 3.
U.A.03.Sb	=	Units added to site b Cards by operator 3.
U.S.03.Sb	=	Units Subtracted from site b Cards by operator 3.
U.A.03.SC	=	Units added to site C Cards by operator 3.
U.S.03.SC	=	Units Subtracted from site A Cards by operator 3.
U.E.03.SA	=	Units Encoded to site A cards by operator 3.
U.E.03.Sb	=	Units Encoded to site B cards by operator 3.
U.E.03.SC	=	Units Encoded to site C cards by operator 3.

The following meters are non-re-settable Grand Totals:

C.A.nr.SA	=	Cash Value added and encoded to Site A cards.
C.S.nr.SA	=	Cash Value subtracted from Site A cards.
C.A.nr.Sb	=	Cash Value added and encoded to Site B cards.
C.S.nr.Sb	=	Cash Value subtracted from Site B cards.
C.A.nr.SC	=	Cash Value added and encoded to Site C cards.
C.S.nr.SC	=	Cash Value subtracted from Site C cards.
C.E.nr.SA	=	Cash encoded to Site A cards.
C.E.nr.Sb	=	Cash encoded to Site B cards.
C.E.nr.SC	=	Cash encoded to Site C cards.

U.A.nr.SA	=	Units added to Site A cards.
U.S.nr.SA	=	Units subtracted from Site A cards.
U.A.nr.Sb	=	Units added to Site B cards.
U.S.nr.Sb	=	Units subtracted from Site B cards.
U.A.nr.SC	=	Units added to Site C cards.
U.S.nr.SC	=	Units subtracted from Site C cards.
U.E.nr.SA	=	Units encoded to Site A cards.
U.E.nr.Sb	=	Units encoded to Site B cards.
U.E.nr.SC	=	Units encoded to Site C cards.

To print out the meters to a serial printer, plug the supplied cable into the 9-pin connector at the back of the Till, then insert the read meters card. With the printer attached and on line, the report will automatically be sent to the printer instead of the display. Printing the 1035 meter readings will show the following readings.

IMPORTANT NOTE References to “Cash or Units value added...” Reflect the value added PLUS value encoded for that category.

1035 METER READINGS

Operator 1

Cash value added to Site A:
\$ 0.000
Cash value deducted from Site A:
\$ 0.000
Cash value added to Site B:
\$ 0.000
Cash value deducted from Site B:
\$ 0.000
Cash value added to Site C:
\$ 0.000
Cash value deducted from Site C:
\$ 0.000
Cash cards encoded with Site A code:
0
Cash cards encoded with Site B code:
0
Cash cards encoded with Site C code:
0
Units added to Site A cards:
0
Units deducted from Site A cards:
0
Units added to Site B cards:
0
Units deducted from Site B cards:
0
Units added to Site C cards:
0
Units deducted from Site C cards:
0
Unit cards encoded with Site A code:
0
Unit cards encoded with Site B code:
0
Unit cards encoded with Site C code:
0

Operator 2

Cash value added to Site A:

\$ 0.000

Cash value deducted from Site A:

\$ 0.000

Cash value added to Site B:

\$ 0.000

Cash value deducted from Site B:

\$ 0.000

Cash value added to Site C:

\$ 0.000

Cash value deducted from Site C:

\$ 0.000

Cash cards encoded with Site A code:

0

Cash cards encoded with Site B code:

0

Cash cards encoded with Site C code:

0

Units added to Site A cards:

0

Units deducted from Site A cards:

0

Units added to Site B cards:

0

Units deducted from Site B cards:

0

Units added to Site C cards:

0

Units deducted from Site C cards:

0

Unit cards encoded with Site A code:

0

Unit cards encoded with Site B code:

0

Unit cards encoded with Site C code:

0

Operator 3

Cash value added to Site A:

\$ 0.000

Cash value deducted from Site A:

\$ 0.000

Cash value added to Site B:

\$ 0.000

Cash value deducted from Site B:

\$ 0.000

Cash value added to Site C:

\$ 0.000

Cash value deducted from Site C:

\$ 0.000

Cash cards encoded with Site A code:

0

Cash cards encoded with Site B code:

0

Cash cards encoded with Site C code:
0
Units added to Site A cards:
0
Units deducted from Site A cards:
0
Units added to Site B cards:
0
Units deducted from Site B cards:
0
Units added to Site C cards:
0
Units deducted from Site C cards:
0
Unit cards encoded with Site A code:
0
Unit cards encoded with Site B code:
0
Unit cards encoded with Site C code:
0

Operator 4

Cash value added to Site A:
\$ 0.000
Cash value deducted from Site A:
\$ 0.000
Cash value added to Site B:
\$ 0.000
Cash value deducted from Site B:
\$ 0.000
Cash value added to Site C:
\$ 0.000
Cash value deducted from Site C:
\$ 0.000
Cash cards encoded with Site A code:
0
Cash cards encoded with Site B code:
0
Cash cards encoded with Site C code:
0
Units added to Site A cards:
0
Units deducted from Site A cards:
0
Units added to Site B cards:
0
Units deducted from Site B cards:
0
Units added to Site C cards:
0
Units deducted from Site C cards:
0
Unit cards encoded with Site A code:
0
Unit cards encoded with Site B code:
0
Unit cards encoded with Site C code:
0

Operator 5

Cash value added to Site A:

\$ 0.000

Cash value deducted from Site A:

\$ 0.000

Cash value added to Site B:

\$ 0.000

Cash value deducted from Site B:

\$ 0.000

Cash value added to Site C:

\$ 0.000

Cash value deducted from Site C:

\$ 0.000

Cash cards encoded with Site A code:

0

Cash cards encoded with Site B code:

0

Cash cards encoded with Site C code:

0

Units added to Site A cards:

0

Units deducted from Site A cards:

0

Units added to Site B cards:

0

Units deducted from Site B cards:

0

Units added to Site C cards:

0

Units deducted from Site C cards:

0

Unit cards encoded with Site A code:

0

Unit cards encoded with Site B code:

0

Unit cards encoded with Site C code:

0

Non-Resettable Totals:

Cash value added to Site A:

\$ 0.000

Cash value deducted from Site A:

\$ 0.000

Cash value added to Site B:

\$ 0.000

Cash value deducted from Site B:

\$ 0.000

Cash value added to Site C:

\$ 0.000

Cash value deducted from Site C:

\$ 0.000

Cash cards encoded with Site A code:

0

Cash cards encoded with Site B code:

0

Cash cards encoded with Site C code:

0

Units added to Site A cards:

0

Units deducted from Site A cards:

0

Units added to Site B cards:
0
Units deducted from Site B cards:
0
Units added to Site C cards:
0
Units deducted from Site C cards:
0
Unit cards encoded with Site A code:
0
Unit cards encoded with Site B code:
0
Unit cards encoded with Site C code:
0

9. CLEARING METERS

Use the **CLEAR METERS** card in the conventional manner. **REMEMBER**, the front panel button must be depressed and held while the **CLEAR METERS** card is inserted and Switch 6 on SW 1 must be **ON**.

To clear the meters:

1. Push and hold the front push button.
2. Insert the clear meters card. The card will be read then ejected. The display will read **“CLEAR”**.
3. Remove the card.
4. Release the push button.

10. ERROR CODE SUMMARY

DISPLAY	PROBLEM
ER 1 - (Er. 1)	A Card was not properly inserted or something is blocking one of the sensors
ER 2 - (Er. 2)	Blank Card Inserted: Card was not encoded or inserted backwards
ER 3 - (Er. 3)	No Start Byte Encountered: Defective data on card or ROM Code on Bank SW2 incorrect
ER 4 - (Er. 4)	No ROM Code Encountered: incompatible card on ROM Code on Bank SW2 incorrect
ER 5 - (Er. 5)	Field Error: Defective data on card
ER 6 - (Er. 6)	No End Byte Found: Defective data on card
ER 7 - (Er. 7)	LRC Not Correct: Defective data on card
ER 8 - (Er. 8)	LRC is Inverted (Flagged): Card was removed manually during a power off state
ER 9 - (Er. 9)	Site Code Error (the card is from another system): Check that the proper site code is set
ER 10 - (Er. 10)	Maximum Card Value Exceeded: i.e. Card exceeds LG Units or LG Unit setting
ER 11 - (Er. 11)	Prices are set to Zero: Check parameters Units and/or units
ER 12 - (Er. 12)	Motor Speed Error: Problem with card reader
ER 13 - (Er. 13)	Command Card Switch Not "ON": Switch 6 on Bank must be on to encode, clear meters or set parameters
ER 14 - (Er. 14)	Illegal User Card: Card cannot be used with this system
ER 15 - (Er. 15)	Illegal Command Card:

- ER 17 - (Er. 17) Illegal Card Format: To accept cards from older systems switch 1 on Bank A must be off
- ER 19 - (Er. 19) Memory Error
- ER. 22 - (Er. 22) Parameter settings are corrupted
- ER 24 - (Er. 24) Card return button was not depressed when the "Clear Meter Card" was used.
- ER 26 - (Er. 26) Value Card was inserted while no operator was logged in (LOG-IN on display)

Other Error Codes may indicate a defective card or memory problem with the Mini Till.

11. USING AN OPTIONAL PRINTER.

The 1035 Version 346 1.02 is capable of printing receipts and/or meter readings to an optional serial printer. Contact Boscop Inc. to purchase a compatible printer and/or cable.

To print receipts for each transaction:

1. Connect the printer to the 9 pin serial port on the back of the Till.
2. Ensure that the printer is configured to match the communication parameters that are settable by the printer parameter.
3. Turn the printer on, load the paper and put the printer "On Line".
4. Each transaction that occurs will print a receipt similar to the sample below.
5. Tear off the receipt and you are ready for the next transaction.

CARD TRANSACTION RECEIPT

Terminal #1

Beginning card value \$ 100.00

Transaction amount - \$ 100.00

Final card value \$ 0.00

Serial Printer to 1035 346V1.02 Cable

1035
9 Pin Male

Printer
25 Pin Male

Printer
9 Pin Male

2 Data
5 Ground

BLACK
GREEN

2 Data
7 Ground

3 Data
5 Ground

7 }
8 } Must be tied together
3 }

1035 Printer Setting in Parameters:

Printer = 96 n.8.1

Printer Settings:

Serial Input
 Auto Line Feed ON
 80 columns ON
 USA Character Set ON
 Data Length 8 bits
 Parity Disabled or NO
 Busy Control X ON X OFF
 Baud 9600

1035 346V1.0X to PC Serial Communication Cable

1035 9 Pin Male	PC 25 Pin Female	PC 9 Pin "D" Female
2 Tx	3 Rx	2 Rx
5 GND	7 GND	5 GND
7 } 8 } Must be tied together 3 }	4 RTS 5 CTS 6 DSR	7 RTS 8 CTS 6 DSR
Must be tied together	8 DCD 20 DTR 22 RI	1 DCD 4 DTR 9 RI

12. CAPTURING 1035 METER READINGS WITH HYPER-TERMINAL

1. Obtain the cable that will attach the PC to the 1035. Connect the Male end to the 9 pin port on the rear of the 1035. Connect the other (female) end to the rear of the computer into an available Com port. Set up the "Printer" parameter on the 1035 for 96 n.8.1. The cable specifications are on page 18 of the 1035 manual: 1035 346V 1.0X to PC serial communication cable
2. Launch Hyper-terminal on the computer. by double clicking on the Hyperterm.exe Icon.
3. Enter a new connection Name: 968N1.HT when prompted by the computer. Select "OK" to continue. On the next screen when prompted for a phone number leave the entry blank, go to the bottom selection bar Titled: "Connect using" and select "Direct to com 1" (or the Com port being used on the computer). Select "OK" at the bottom of the window.
4. In the COM 1 properties: Port Settings Select:
 - Bits per second 9600
 - Data bits 8
 - Parity None
 - Stop bits 1
 - Flow control None
 - Select **OK** at the bottom of the window.

5. Select File from the main menu bar, then select Properties. Select the Settings tab then the ASCII Setup... button. Under "ASCII Receiving" check off the box marked "Append line feeds to incoming line ends". Select the OK button at the bottom of the ASCII Setup window. Select the OK button at the bottom of the Properties window to register the settings.
6. Select Transfer on the main menu bar then select Capture text. At this point a window will pop up labeled "Capture Text" and prompt for a file name to be entered. An appropriate file name such as "1035meter.txt" is to be entered in the File selection bar. Select the "Start" button to begin the communications session.
7. Insert the read meters card into the 1035. The meters will be displayed on the main screen of the hyper terminal program.
8. Once the meters are finished scrolling select "Transfer" under the main menu bar and under "Capture Text" select "Stop". The meter readings have now been saved to a file that was specified in step 6 (1035meter.txt). The txt file can be opened or manipulated as desired through an appropriate application such as Wordpad.
9. Close the hyper terminal application and select "YES" when prompted to disconnect. When prompted to save the session "96N81.", selecting yes will create an icon under the hyper terminal folder named 96N81.HT In future, double clicking on the "96N81.HT" icon created above will launch the hyper-terminal application with the settings preset so that the meters are ready to be captured immediately starting at step 7.

Cash Card Reader Installation Data

Model: 1035 Version 1.02 Serial #: _____

Date _____ Customer _____ Building _____
 Address _____
 City _____ State _____ Zip _____
 Contact _____ Tel _____ Fax _____

DIP SWITCH SETTINGS

BANK "A" (ON) _____ BANK "B" (ON) _____ ROM CODE _____
 BANK "C" (ON) _____
 SITE CODE 1 _____ SITE CODE 2 _____ SITE CODE 3 _____

PARAMETER SETTINGS

id# _____ tEntH.d _____ HOLD _____
 OPer 1 _____ OPer 2 _____ OPer 3 _____
 OPer 4 _____ Oper 5 _____ Op.1..Add _____
 Op.2..Add _____ Op.3..Add _____ Op.4..Add _____
 Op.5.Add _____ Prnter _____
 SITE A _____ SITE B _____ SITE C _____

COMMENTS

13. FREQUENTLY ASKED QUESTIONS

ADD VALUE STATIONS

If an error message occurs refer to the Error list provided in the manual.

Unable to add or subtract value onto a card.

Readers that are less than 2 years old follow this procedure: insert card, type in value, then either ADD or SUBTRACT and finally Enter.

How to login the 1035 and log-out the unit.

Insert either operator cards 1-5 and the display will go to the HELLO message.

Trying to add value and the keypad does not beep.

Check to make sure that the keypad is plugged into the back of the reader. If yes, then consult an Boscop Inc. Technician.

The Operator 2 card does not allow the user to log-in. Why?

Check to see if the Operator 2 parameter card is enabled in the parameter settings using the Command card SET PARAMETERS.

14. EXPLANATION OF TERMS USED IN SERVICE

- Audit Report Printer:** An optional serial printer that can be attached to the printer output jack on the main board. When the printer is attached and the device is requested to print, a hard copy of the account information will be printed. Refer to the specific product manual for details.
- Card Format:** The format of the data on the card is referred to as card format. Often the format is named after the company that manufactures the readers that utilize it. I.e. ITC Format, ACT Format, Daynl, XCP etc Some formats are named for card the issuing body such as MONDEX or VISACASH. Many Boscop readers can be setup to read other formats of cards through settings and or specific firmware revisions.
- Card Reader:** Device that accepts the card, determines the value of the card and transfers the value of the card to the control board or enables the copier, etc. When the transaction is finished and the eject button is pushed, the Card Reader writes the new value onto the card and returns the card to the customer. The Card Readers used are the 10XX-YY-Z Series where XX = application, YY = card size (CR-50 or CR-80) and, in the case of CR-80, Z determines the track position on the card that the magnetic stripe is located (2, 4, 5).
- Card Size**
/CR-50
/CR-80: Two standard card sizes are the **CR-80** (typical credit card size – approximately 54 mm.) and **CR-50** (narrower card-approximately 44 mm.) These are standard sized based on ISO standards. Two standard

Card Track:	The location of the magnetic stripe on the card. The locations are based upon ISO standards. Some common tracks are 5.5, 2, and 4 and, in the case of CR-50, centered. The advantage to the CR-50 centered track is the card can be read/written from either end. Command Card Switch An internal DIP switch located on the top board of the reader that must be set correctly to allow use of command cards. This is typically switch 6 on bank A (front DIP switch) and it must be in the ON position to allow command cards. For security reasons <u>THIS SWITCH MUST BE TURNED OFF EXCEPT WHEN USING COMMAND CARDS!!!!!!</u>
Command Cards/ Control Cards/ Set-Up Cards	Command Cards are used by various readers to do Administrative tasks. Some of these tasks included: Setting parameters, Reading meters, Clearing meters, Encoding cash or units onto user cards, and logging in or out operators. See Command Card Switch section for important note.
Communication Port:	See Serial Port Section
Control Cards:	See Command Cards
Eject Button:	User accessible button on the front of Card Readers to indicate that the user wants the card returned. This button is also used to set parameters and exit meter-reading routines.
High Field:	A magnetic data stripe with high coercivity in the range of 4000 oersted. This is a higher security medium that takes a much larger magnetic field to encode. Typically, the write CCT drives through a 15-ohm resistor. See Low Field.
LED LCD Display:	The display used to show information on status etc to the user. There are two main types used by Boscop. LED (Light Emitting Diode) and LCD (Liquid Crystal Display) are the proper names for these displays.
Low Field:	A magnetic data stripe with low coercivity in the range of 400 oersted. This is a lower security medium equivalent to a typical bankcard that can easily be affected by a magnetic field. Typically the write CCT drives through a 220 to 330 ohm resistor. See High Field.
Machine ID#:	An arbitrary number the operator can assign to the device to track which unit is making what copies. This number will be printed on the audit reports if an audit report printer is used. This ID number is critical for POS cash register use where it must be set to 1.
Null:	Null is used by some devices in order to slow down the data stream going to the report printer. Most small printers have limited buffer memory and slow printing speeds. Null is a wait state between lines sent to the printer so the printer can “keep up”. Very large settings may be required for long reports. Trial and error is required to set the settings. Indication of a Null that is set too low would be cut off, data in the report and columns not lining up.

Parameter / Option / Command:	Administrator settable variables to determine how the system will function, values to be charged, card compatibility, etc. These are either numerical values, ON/OFF, Yes / No, or similar choices. See power Supply section.
Power Supply/ Power Adapter/ Transformer	A Class 2 device (wall plug type) that converts the 120 volt power supplied by the mains to a lower AC or DC Voltage. This lower voltage (typically 9 to 24 volts) is then utilized by the controller. Using a class 2 device makes the product safer as there is no direct path to 120 Volts.
Printer Settings:	Typically printers are used to obtain meter and audit readings. To allow for maximum versatility, most printers and many controllers have settable parameters include: Baud Rate, Parity, Data Bits, Stop Bits, Null Characters, etc. The settings of the printer and controller must match for proper printout. See Null for explanation.
Receipt Printer:	The receipt printer is a small printer dedicated to printing receipts for transactions as they take place. There are receipt printers available for the 1040 Plus and 1035.
ROM Code:	This is the last digit in the ROM Group Code (see STX Code for proper settings).
Serial Port: Communication Port/ Key Account Software/ Actors Software	Some devices (1040 Plus, 7500, 1010, etc) have a built-in serial communication port to interact with a computer or Audit Report Printer to report meter readings. Special communications packages are also available for some devices to upload and download information including parameters, account information and meter readings. (i.e. 7500 & Key Account 1010 and Actors)
Set-up Cards	See Command Cards
Site Code:	This is a unique code assigned to the location so only cards at that location can be used. Site Codes are assigned in groups called ROM groups (see ROM and STX). Up to 3 Site Codes can be set on each Coin-Op for different pricing applications.
Software / Firmware:	The program that runs within the controller. Contained on an EPROM (or, in some cases, a microprocessor), it can be easily upgraded by exchanging the EPROM. NOTE: EPROMS are very fragile and sensitive to static electricity so handling precautions should be observed. The label on the EPROM does not necessarily indicate the orientation of the EPROM to the socket! Always double check that the notch on the EPROM matches the notch on the socket.
STX Code:	This is the first digit(s) in the ROM Group. This is set by determining the start byte(s) of the ROM Group Code. For example, in ROM Group C1A, the start byte is "C". This is entered in DECIMAL (i.e. 12) at the parameter STX Code.

ROM Group	STX Code	ROM Code
B9A	11	9
C0A	12	0
C1A	12	1
C2A	12	2
E70	231	0
E71	231	1
40A	4	0

Transformer: See Power Supply section

Troubleshoot: To diagnose a specific problem or malfunction in a device through the process of elimination of working functions and components vs. non-working functions and components through a logical, methodical approach and process.

15. WARRANTY

Warranty

This product is guaranteed to the original purchaser for a period of one (1) year from original purchase date against defective materials and workmanship when used under normal operating conditions. The repair or replacement of any defective component or part and any necessary adjustments will be made free of charge provided that the machine is shipped securely packaged and prepaid to the service department at the address below. The guarantee is not applicable if the device has been subject to misuse, abuse, negligence, dropped and/or spillage accidents, power surges, fire, lightning or third party acts. The guarantee is not applicable if the serial number has been altered, defaced, or removed or if the device has been tampered with or taken apart by other than authorized service personnel.

WARRANTY REGISTRATION CARD

Fill out information below. Please Print:

Model # _____ Serial No. _____

Purchased from (Dist.) _____

Address _____

City _____ State _____ Zip _____ Installed On: _____